

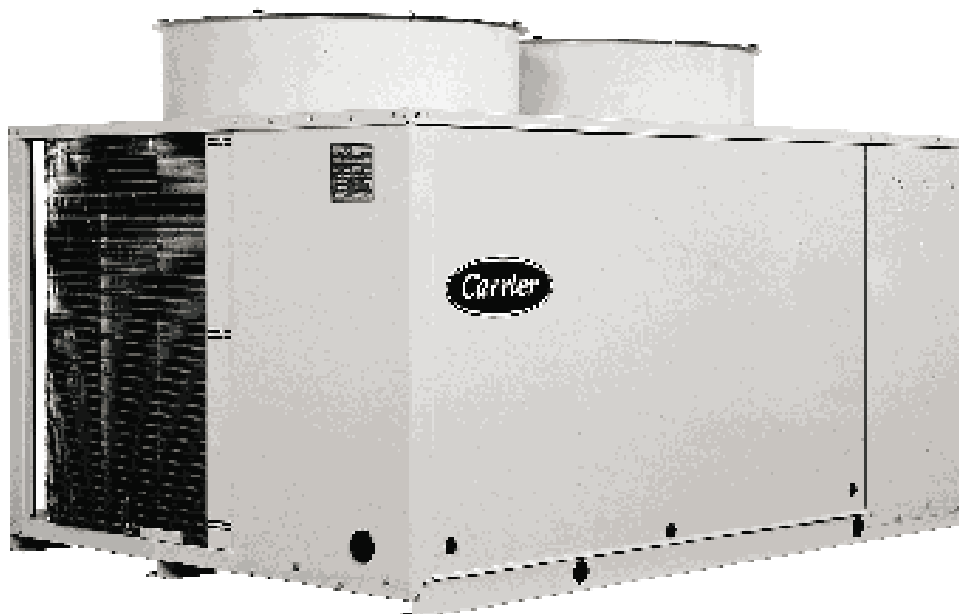

30GH/GZ 009-035

Air-Cooled Liquid Chillers

50 Hz



Installation, Operation and Maintenance Instructions



Dimensions and clearances (standard unit)

30GH/GZ	A	B	C	D	E	F	G
009-013	1160	1220	1060	1200	1000	1000	1000
015-025	1720	1160	1112	1200	1000	1000	1000
030-035	2060	1370	1231	1200	1000	1000	1200

All dimensions are given in mm.

Legend:

Required service clearance

Power supply

Water inlet

Water outlet

Note:
Certified drawings are available on request.

30GH and 30GZ 009-013

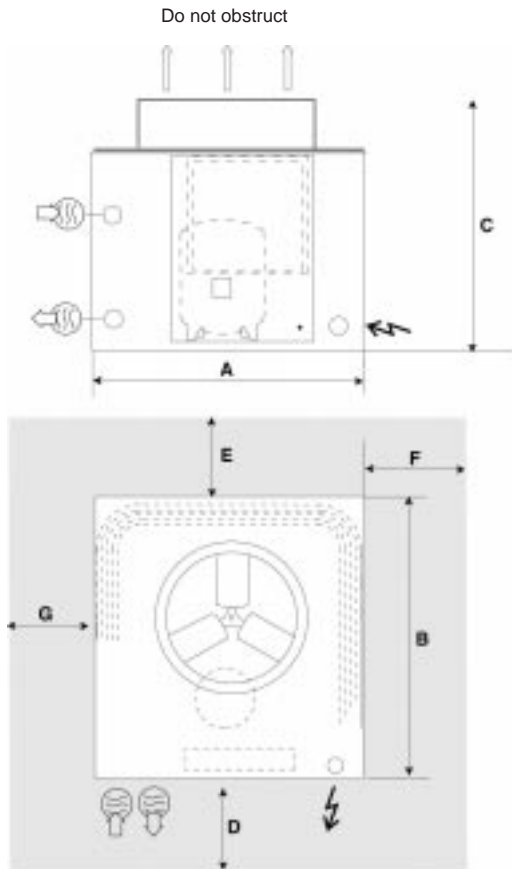

30GH and 30GZ 015-025

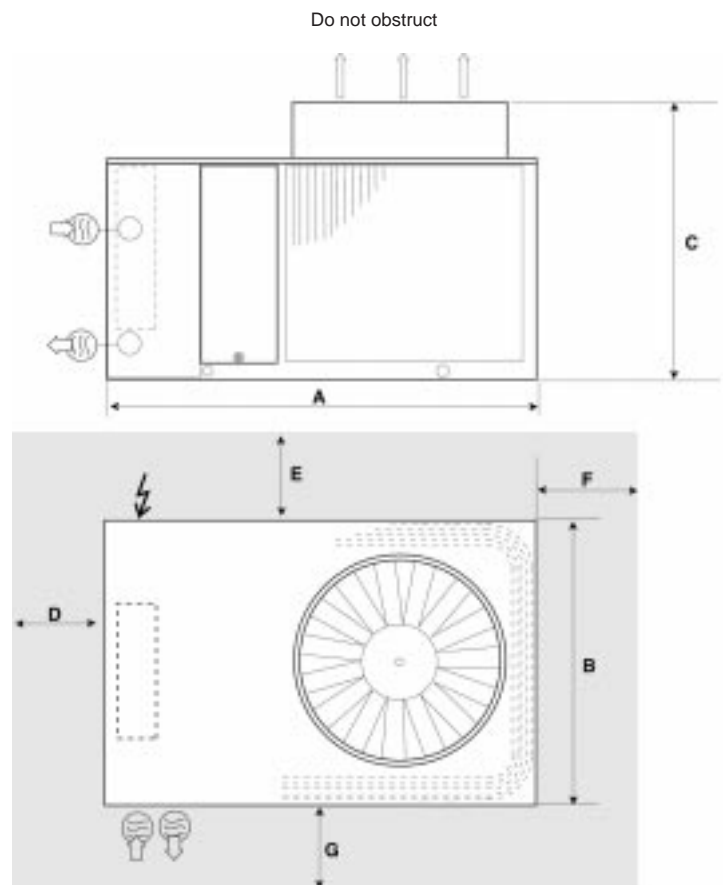

Do not obstruct

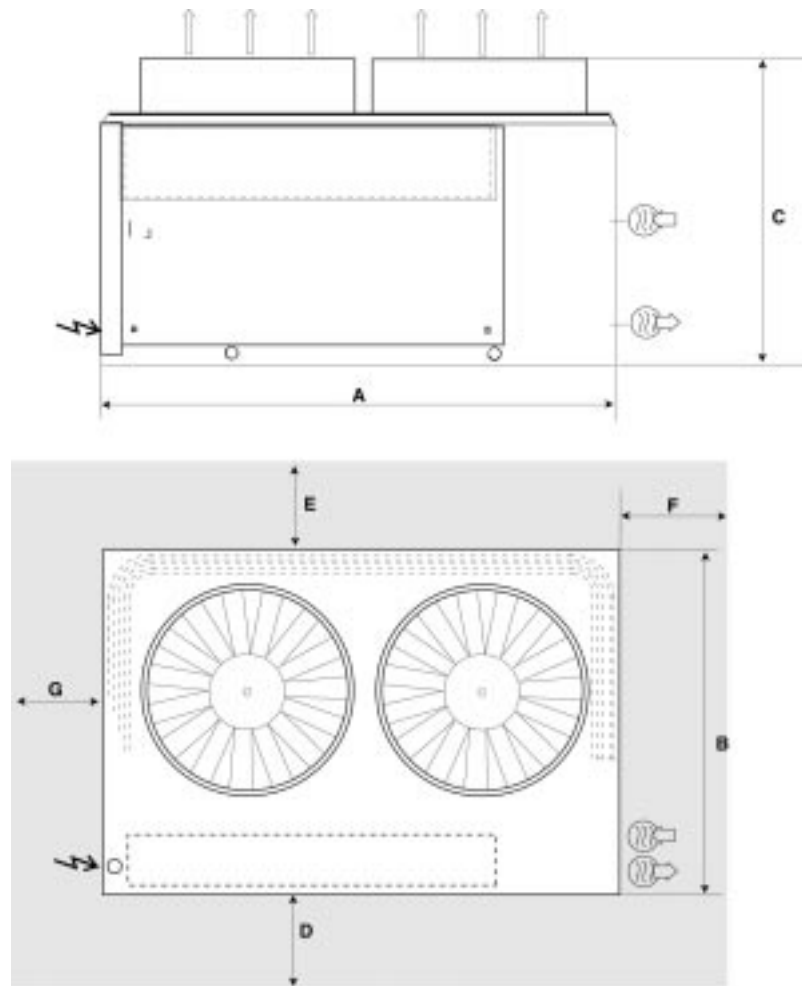

Floor mounting

- For unit mounting holes, weight distribution and centre of gravity coordinates, refer to the dimensional drawings.
- These units are designed for outdoor installation.

CAUTION:

- Ensure the air flow around the unit is not obstructed.
- If several units are installed, next to each other, ensure that the space in between the units is the same as the unit depth.
- There must not be any roof or cover above the unit.

Dimensions and clearances (unit with optional Hydroflow kit)

CAUTION: ONLY PRO-DIALOG UNITS CAN BE EQUIPPED WITH THE OPTIONAL HYDROFLOW KIT.

30GH/GZ	A	B	C	D	E	F	G
009-013	1160	1310	1781	1200	1000	1000	1000
015-025	1720	1246	1833	1200	1000	1000	1000
030-035	2150	1370	2052	1200	1000	1000	1200

All dimensions are given in mm.

Legend:

Required service clearance

Power supply

Water inlet

Water outlet

Note:
Certified drawings are available on request.

30GH and 30GZ 009-013

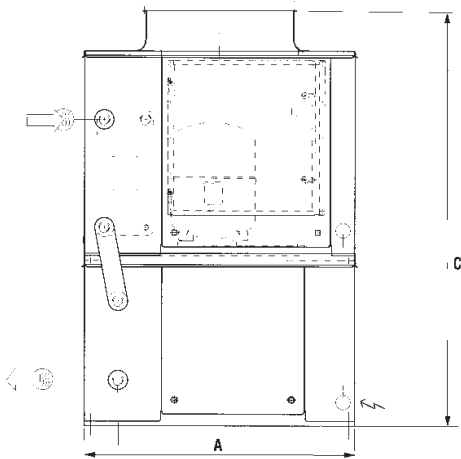

30GH and 30GZ 015-025

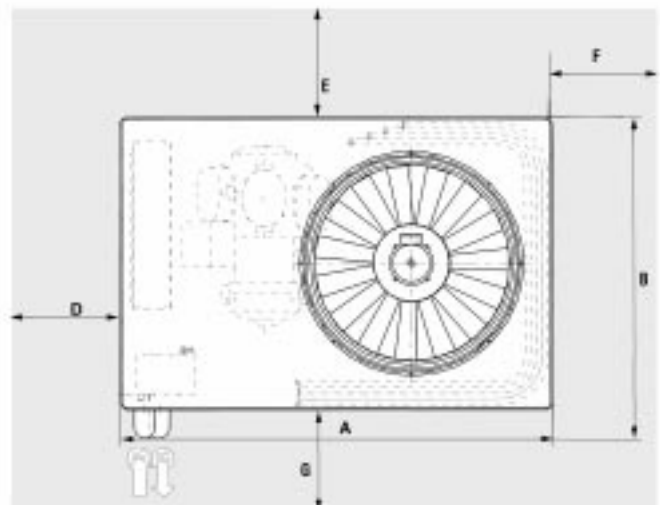
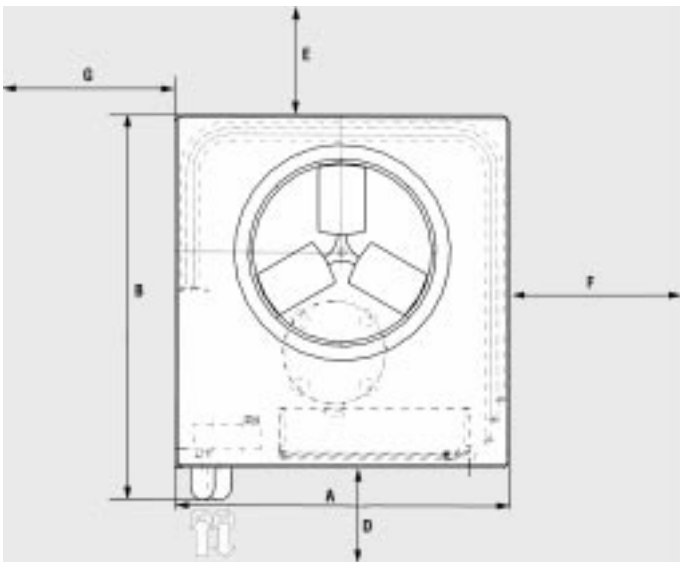
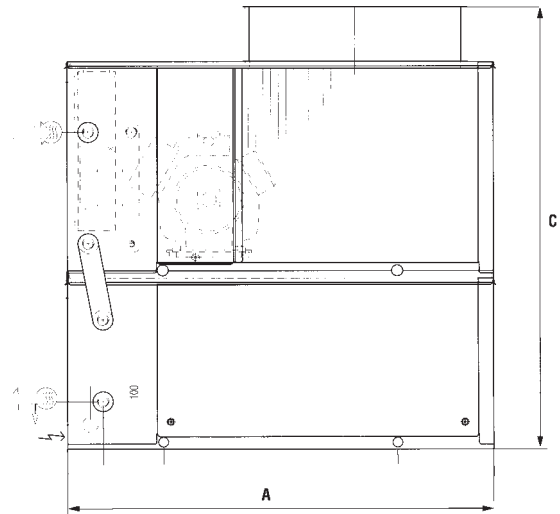

30GH and 30GZ 030-035

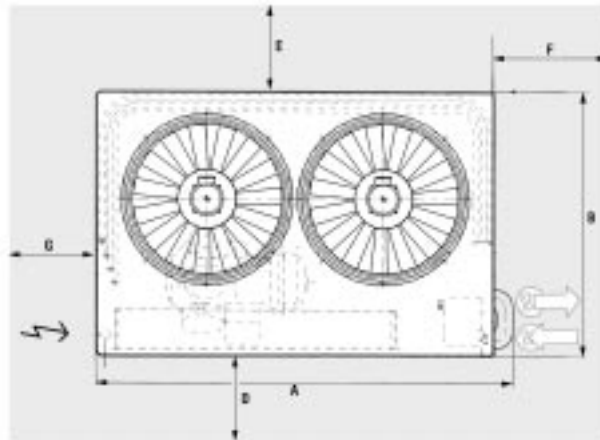
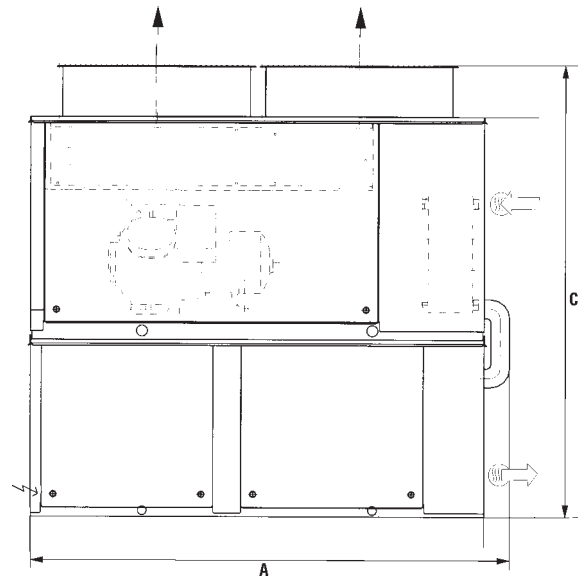

Floor mounting

- For unit mounting holes, weight distribution and centre of gravity coordinates, refer to the dimensional drawings.
- These units are designed for outdoor installation.

CAUTION:

- Ensure the air flow around the unit is not obstructed.
- If several units are installed, next to each other, ensure that the space in between the units is the same as the unit depth.
- There must not be any roof or cover above the unit.

Physical data

Size		009	013	015	020	025	030	035
Net nominal cooling capacity 30GH*	kW	21.2	31.6	40.1	52.0	64.0	74.0	93.0
Net nominal cooling capacity 30GZ*	kW	21.0	32.0	41.0	53.0	65.0	75.0	94.0
Operating weight	kg	265	283	400	460	510	682	725
Refrigerant charge (R-22 - 30GH)	kg	6.5	8.0	9.2	11.9	13.3	15.7	16.5
Refrigerant charge (R-407C - 30GZ)	kg	7.5	9.0	10.5	13.5	15.0	15.7	18.6
Compressor		1 ... hermetic, 48.3 r/s		1 ... semi-hermetic, 4 or 6 cylinders, 24.2 r/s				
Control type		PRO-DIALOG or electromechanical						
Capacity control steps		1	1	2	2	2	2	2
Minimum capacity step	%	100	100	66	50	66	66	66
Evaporator		Direct-expansion, plate heat exchanger						
Water volume	l	1.9	2.8	3.8	4.7	5.6	6.6	7.5
No. of refrigerant circuits		1	1	1	1	1	1	1
Water connections	in	Gas thread						
Inlet/outlet		1-1/2	1-1/2	1-1/2	1-1/2	1-1/2	1-1/2	1-1/2
Max. water side operating pressure	kPa	1000	1000	1000	1000	1000	1000	1000
Condenser		Copper tube, aluminium fins			Low-noise shrouded axial Flying Bird fan			
Fans		Propeller						
Quantity		1	1	1	1	1	2	2
Total air flow	l/s	2640	2640	4700	4700	4700	9400	9400
Fan speed**	r/s	15.8/12.5	15.8/12.5	12.5	12.5	12.5	12.5	12.5
OPTIONAL HYDROFLOW KIT								
Nominal water flow rate	l/s	1	1.5	3.0	2.5	3.1	3.6	4.5
Available pressure	kPa	70	36	72	62	45	60	59
Unit operating weight	kg	297	616	854	915	966	1369	1413
Buffer tank capacity	l	100	100	150	150	150	300	300
Expansion tank capacity	l	8	18	18	18	18	24	24
Water volume	l	112	113	174	175	176	337	338
Water connections								
Inlet	in	1-1/2	1-1/2	1-1/2	1-1/2	1-1/2	1-1/2	1-1/2
Outlet	in	1-1/4	1-1/4	1-1/2	1-1/2	1-1/2	2-1/2	2-1/2

* Net cooling capacity = gross cooling capacity minus the water pump heat against the internal evaporator pressure drop.

Evaporator entering/leaving water temperature 12°C and 7°C. Condenser entering air temperature 35°C.

** The first figure is for the standard fan, the second figure is for the optional low speed fan.

Electrical data

Size		009	013	015	020	025	030	035
Power supply								
Nominal power supply	V-ph-Hz	400-3-50						
Voltage range	V	360-440						
Auxiliary circuit	V-ph-Hz	230-1-50						
Auxiliary circuit power input (heaters)	W	70	70	110	250	250	250	250
Fan power input	kW	0.80	0.80	1.15	1.15	1.15	2.30	2.30
Fan power supply	V-ph-Hz	400-3-50						
Nominal unit power input*	kW	8.4	13.7	13.6	18.2	24.2	26.9	37.8
Maximum unit power input**	kW	10.0	16.8	16.4	22.0	29.0	32.3	46.2
Maximum unit starting current	A	83.2	136.7	87.0	107.0	134.0	158.0	213.0
Nominal unit current drawn*	A	13.2	22.5	21.1	29.0	39.3	42.1	60.7
Maximum unit current drawn**	A	24.7	38.7	34.0	38.9	51.0	60.0	83.0
UNIT WITH OPTIONAL HYDRAULIC KIT								
Nominal unit power input*	kW	8.9	14.2	14.3	18.9	24.9	28.3	39.2
Maximum unit power input**	kW	10.6	17.4	17.2	22.8	29.8	33.8	47.7
Maximum unit starting current	A	84.5	138.0	88.7	108.7	135.7	161.0	216.0
Nominal unit current drawn*	A	14.4	23.7	27.7	30.6	40.9	45.0	63.6
Maximum unit current drawn**	A	26.0	40.0	35.7	40.6	52.7	62.9	85.9
Heater power input	W	120	120	150	150	150	220	220

* Evaporator entering/leaving water temperature 12°C and 7°C. Condenser entering air temperature 35°C.

** Evaporator entering/leaving water temperature 18°C and 13°C. Condenser entering air temperature 45°C. Currents are given at nominal voltage.

NOTES:

- 30GH/GZ 009-035 units have a single power connection point.
 - A separate power source (230 V, 1 ph, 50 Hz) that does not exceed the main switch capacity is required to power the compressor crankcase heater circuit. This source must be supplied from a transformer. It must not be supplied from a phase + neutral supply (for ground + neutral systems).
 - The control box includes the following standard features:
 - Starter and motor protection devices for each compressor and the fan(s)
 - Control devices
 - **Field connections:**

All connections to the system and the electrical installations must be in full accordance with all applicable codes.
 - The Carrier 30GH/GZ 009-035 chillers are designed and built to ensure conformance with local codes. The recommendations of European standard EN 60 204-1 (machine safety - electrical machine components - part 1: general regulations) are specifically taken into account, when designing the electrical equipment.
 - Conformance with EN 60 204 is the best means of ensuring compliance with the Machines Directive and §1.5.1. Generally the recommendations of IEC 364 are accepted as compliance with the requirements of the installation directives.
 - Annex B of EN 60204-1 describes the electrical characteristics used for the operation of the machines.
1. The operating environment for the 30GH/GZ 009-035 chillers is specified below:
 - Environment* - Environment as classified in IEC 60 721:
 - outdoor installation*
 - ambient temperature range: -18°C to +46°C, class 4K4H*
 - altitude: ≤ 2000 m*
 - presence of hard solids, class 4S2 (no significant dust present)
 - presence of corrosive and polluting substances, class 4C2 (negligible)
 - vibration and shock, class 4M2
 - Competence of personnel, class BA4* (trained personnel - IEC 364)
- * The protection level required to conform to this class is IP43BW (according to reference document IEC 529). All 30GH/GZ 009-035 units are protected to IP44CW and fulfill this protection condition.
2. Power supply frequency variation: ± 2 Hz.
 3. The neutral (N) line must not be connected directly to the unit (if necessary use a transformer).
 4. Overcurrent protection of the power supply conductors is not provided with the unit.
 5. The factory-installed circuit breaker is of type “a” (EN 60 204-1 § 5.3.2).

NOTE: If particular aspects of an actual installation do not conform to the conditions described above, or if there are other conditions which should be considered, always contact your local Carrier representative.

APPLICATION DATA (STANDARD UNIT)

Minimum evaporator water flow rates

30GH/GZ	Min. flow rate, l/s
009	0.3
013	0.5
015	0.7
020	0.8
025	1.0
030	1.2
035	1.3

If the flow rate is lower, follow the recommendations below:

- It is possible to install several chillers of lower capacity in series, each one supplying a part of the ΔT .
- The water from the evaporator can be recirculated, in order to increase the flow rate. The temperature of the mixed water entering the evaporator must be at least 2.8 K higher than the leaving water temperature.

Maximum evaporator chilled water flow rate

This is limited by the maximum permitted evaporator pressure drop.

30GH/GZ	Max. flow rate, l/s
009	2.2
013	3.2
015	4.0
020	5.3
025	6.5
030	7.3
035	9.2

The minimum temperature difference is 2.8 K which corresponds to a water flow rate of 0,9 l/s per kW.

Water loop volume

Whatever the size of the system, the water loop minimum volume is given by the following formula:

$$\text{Volume} = \text{CAP (kW)} \times N^* = \text{litres}$$

where CAP is the nominal system capacity (kW) at the nominal operating conditions of the installation.

Application	N*
Air conditioning	3.25
Industrial process cooling	6.5
Low temperature operation	10.8

This volume is necessary for stable operation and accurate temperature control.

It is often necessary to add a storage tank to the circuit in order to achieve the required volume. The tank must itself be internally baffled in order to ensure proper mixing of the liquid (water or brine). Refer to the examples below.

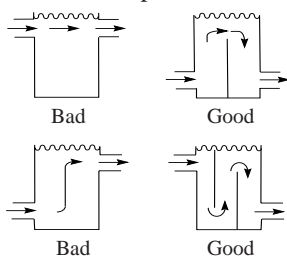

NOTE: The compressor must not restart more than 10 times in an hour.

30GH Operating range

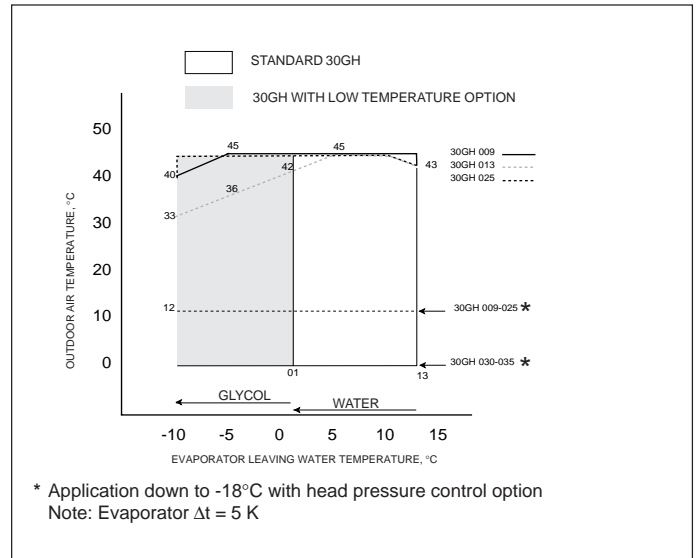

30GZ Operating range

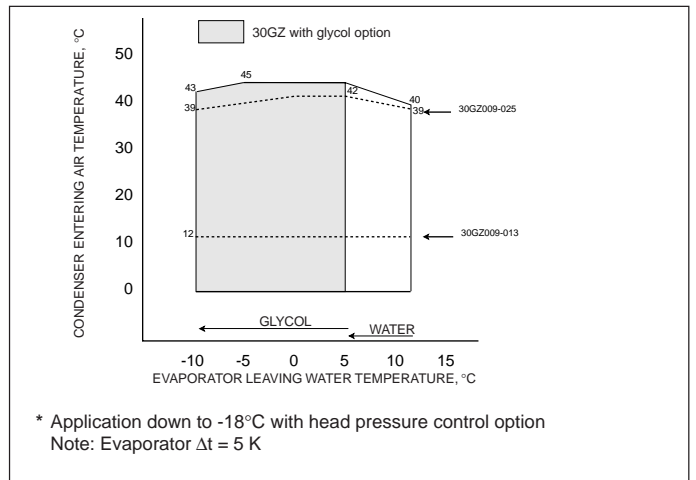

Evaporator pressure drop curve

